

SECTION : 9T

IMMOBILIZER ANTI-THEFT SYSTEM

CAUTION : *Disconnect the negative battery cable before removing or installing any electrical unit or when a tool or equipment could easily come in contact with exposed electrical terminals. Disconnecting this cable will help prevent personal injury and damage to the vehicle. The ignition must also be in LOCK unless otherwise noted.*

TABLE OF CONTENTS

<p>SPECIFICATIONS 9T-1</p> <p style="padding-left: 20px;">FASTENER TIGHTENING SPECIFICATIONS 9T-1</p> <p>SPECIAL TOOLS 9T-1</p> <p style="padding-left: 20px;">SPECIAL TOOLS TABLE 9T-1</p> <p>DIAGNOSIS 9T-2</p> <p style="padding-left: 20px;">IMMOBILIZER ANTI-THEFT SYSTEM 9T-2</p> <p style="padding-left: 20px;">DTC 53 – PCM/ECM Immobilized Error 9T-2</p> <p style="padding-left: 20px;">KEY STATUS ERRORS 9T-2</p> <p style="padding-left: 20px;">COMMUNICATION BETWEEN IMMOBILIZER AND TEST EQUIPMENT 9T-3</p> <p>MAINTENANCE AND REPAIR 9T-4</p> <p style="padding-left: 20px;">ON-VEHICLE SERVICE 9T-4</p> <p style="padding-left: 20px;">KEY CODING PROCEDURE 9T-4</p>	<p>ID CODE REPROGRAMMING 9T-4</p> <p>TRANSPONDER 9T-5</p> <p>DETECTION COIL 9T-5</p> <p>IMMOBILIZER CONTROL UNIT 9T-8</p> <p>GENERAL DESCRIPTION AND SYSTEM OPERATION 9T-10</p> <p style="padding-left: 20px;">IMMOBILIZER SYSTEM 9T-10</p> <p style="padding-left: 20px;">ELECTRONICALLY CODED KEYS 9T-10</p> <p style="padding-left: 20px;">DETECTION COIL 9T-10</p> <p style="padding-left: 20px;">IMMOBILIZER CONTROL UNIT 9T-10</p> <p style="padding-left: 20px;">SERIAL DATA LINK 9T-11</p> <p style="padding-left: 20px;">POWERTRAIN CONTROL MODULE (PCM)/ENGINE CONTROL MODULE (ECM) 9T-11</p>
---	--

SPECIFICATIONS

FASTENER TIGHTENING SPECIFICATIONS

Application	N•m	Lb-Ft	Lb-In
Immobilizer Control Unit Mounting Bolts	4	–	35
Knee Bolster Mounting Bolts	22	16	–

SPECIAL TOOLS

SPECIAL TOOLS TABLE

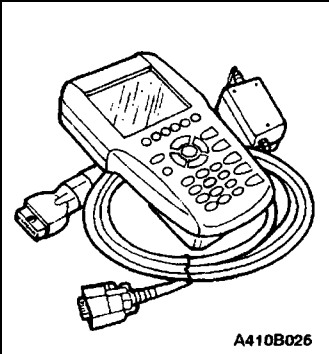
 <p style="text-align: center; font-size: small;">A410B026</p>	<p>Scan Tool</p>
---	------------------

DIAGNOSIS

IMMOBILIZER ANTI-THEFT SYSTEM

The immobilizer anti-theft system requires diagnosis when it is not possible to start the engine. If the no-start condition occurs because of the immobilizer system, a diagnostic trouble code (DTC) 53 should be set.

The immobilizer anti-theft system requires diagnosis when it is not possible to start the engine. If the no-start condition occurs because of the immobilizer system, a diagnostic trouble code (DTC) 53 should be set.

Unauthorized use of a scan tool could be a method of defeating the immobilizer anti-theft system. Therefore, certain scan tool procedures require the use of a password. The following functions are password protected:

- Coding of an additional key.
- Deleting all key codes.
- Deletion of the immobilizer identification (ID) code.
- Deletion of the powertrain control module (PCM)/engine control module (ECM) ID code.

The following functions do not require a password:

- Reading an ignition key to determine if the transponder is working or if a key is authorized.
- Reading the immobilizer ID code to verify that it matches the PCM/ECM ID code.

DTC 53 – PCM/ECM Immobilized Error

Step	Action	Value(s)	Yes	No
1	Connect the scan tool using the following procedure: 1. Insert the immobilizer data cartridge into the scan tool. 2. Turn the ignition OFF. 3. Connect the scan tool to the data link connector (DLC). 4. Turn the ignition ON, but do not start the engine. Is communication established between the scan tool and the immobilizer control unit?		Go to <i>Step 2</i>	Go to "Communication Between Immobilizer and Test Equipment"
2	Select SYSTEM DIAGNOSIS from the scan tool menu. Does the KEY STATUS message indicate POS NR (position number) 00?		Go to "Key Status Errors"	Go to <i>Step 3</i>
3	Read the IMMO & PCM/ECM ID-CODE message that is displayed after requesting SYSTEM DIAGNOSIS. Does the message ID-CODE DIFFERENT appear?		Go to "ID Code Reprogramming"	Go to <i>Step 4</i>
4	Check for an open serial data wire between the immobilizer control unit and the powertrain control module (PCM)/engine control module (ECM). Is the circuit open?		Go to <i>Step 5</i>	Go to <i>Step 6</i>
5	Repair the open serial data wire between the PCM/ECM and the immobilizer control unit. Is the repair complete?		System OK	
6	1. Replace the ECM. 2. Reprogram the identification (ID) code. Refer to "ID Code Reprogramming" in this section. Is the repair complete?		System OK	

KEY STATUS ERRORS

The following KEY STATUS messages may be shown on the scan tool after commanding SYSTEM DIAGNOSIS:

- IGNITION OFF STATUS. This message informs the technician that the ignition is OFF during the key coding process. Turn the ignition ON during key coding, but do not start the engine.

- **KEY IS OCCUPIED.** Only five keys may be coded. If a new key is desired, the previous key codes must be deleted. Up to five keys may then be authorized.
- **ALREADY AUTHORIZED.** Key coding is being attempted with a key that is already authorized.
- **ERROR NO. 001, 002, 003.** There is no communication between the transponder in the ignition key and the detection coil. Follow the steps below to diagnose the problem:
 1. Try a different key. If a different key works, the problem is in the original key.
 2. If trying a different key results in the same error message, replace the detection coil.
- **INVALID KEY.** The communication between the immobilizer control unit and the key transponder has not validated the key. Follow the steps below to diagnose the problem:
 1. Code the key. Refer to "Key Coding Procedure" in this section.
 2. If the same message is received after key coding, check the connection of the detection coil.
 3. If the detection coil is okay, replace the immobilizer. Refer to "Immobilizer Control Unit" in this section.
- **NO TRANSPONDER DETECTED.** The fault may be in ignition key transponder, the detection coil, or the immobilizer. Follow the steps below to diagnose the problem:
 1. Try a different key. If a different key works, the problem is in the original key.
 2. If trying a different key results in the same error message, check the connection of the detection coil.
 3. If the connection of the detection coil is okay, disconnect the detection coil and use an ohmmeter to check for an open detection coil.
 4. If the detection coil is not open, replace the immobilizer control unit. Refer to "Immobilizer Control Unit" in this section.

COMMUNICATION BETWEEN IMMOBILIZER AND TEST EQUIPMENT

1. Connect the test equipment as described in the *Scan Tool Equipment Manual*.
2. If communication between the scan tool and the test equipment is unsuccessful, wait 30 seconds and try again.
3. If communication is not successful on the second try, turn the ignition OFF, and check the wire and the connectors between the immobilizer control unit terminal 3 and the data link connector (DLC).
4. If the wire and the connectors between the DLC and the immobilizer control unit are OK, replace the immobilizer control unit. Refer to "Immobilizer Control Unit" in this section.

MAINTENANCE AND REPAIR

ON-VEHICLE SERVICE

KEY CODING PROCEDURE

1. Install the immobilizer control unit cartridge in the scan tool.
2. Turn the ignition OFF.
3. Connect the scan tool.
4. Turn the ignition ON with the key to be coded.
5. Enter the four-digit password that enables service personnel to use the scan tool for coding keys.
6. A lost key can be deleted only by deleting all keys and reauthorizing the remaining keys as new keys. If a key is lost, go to the next step. If no keys have been lost but an additional key is desired, go to Step 8.
7. Use the scan tool command DELETE ALL KEY CODES.
8. Use the scan tool command AUTHORIZE ONE ADDITIONAL KEY.
9. Repeat Steps 4, 5, and 6 until the immobilizer control unit has recorded all of the new keys or, after a deletion, has reauthorized all of the remaining keys. The immobilizer control unit can record a maximum of five keys.
10. Return the system to the normal mode.
11. Turn the ignition OFF.
12. Turn the ignition ON.
13. Start the engine.

ID CODE REPROGRAMMING

Reprogram the identification (ID) code in the following situations:

1. An immobilizer control unit has been replaced.
2. An electronic control module (ECM) has been replaced.

If a valid key has been lost, refer to "Key Coding Procedure" in this section.

Reprogramming Procedure

1. Turn the ignition OFF. Reprogramming is not allowed while the engine is running.
2. Insert the immobilizer control unit cartridge into the scan tool.
3. Turn the ignition ON, but do not start the vehicle.
4. Enter the four-digit password that enables service personnel to use the scan tool for ID code reprogramming.
5. Use the scan tool to command RESET ID CODE.

6. Turn the ignition OFF and ON again, but do not crank or start the engine. The powertrain control module (PCM)/engine control module (ECM) will reset the ECM ID code to match the new ID code that was calculated and sent by the immobilizer control unit when the ignition was first turned ON after the reset command.
7. Return the system to the normal mode.
8. Turn the ignition OFF.
9. Turn the ignition ON.
10. Start the engine.

After reprogramming the ID code, the scan tool SYSTEM DIAGNOSIS command can verify that the PCM/ ECM ID code matches the immobilizer control unit ID code.

If the reprogramming procedure does not result in matching ID codes, check the electrical connectors for the serial data wire between the immobilizer control unit and the PCM/ECM.

TRANSPONDER

If a transponder is faulty, the ignition key must be replaced. It is not possible to install a new transponder into a key.

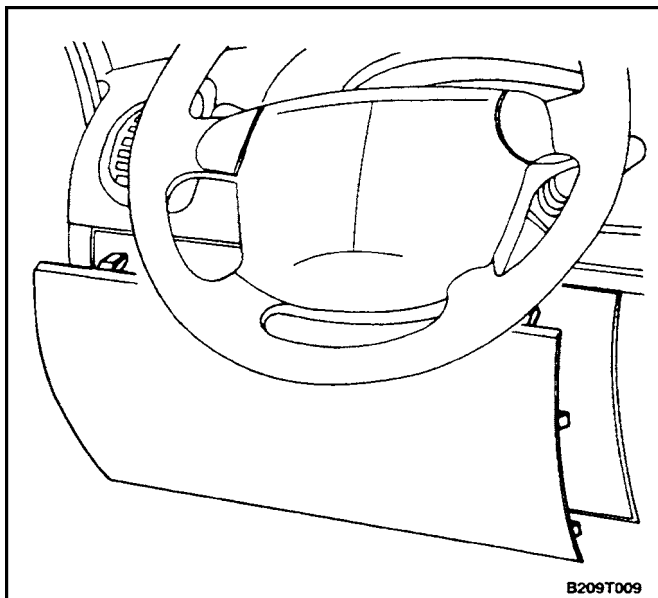

DETECTION COIL

Removal Procedure

1. Carefully pull the knee bolster trim panel until it is loose from its retaining clips.

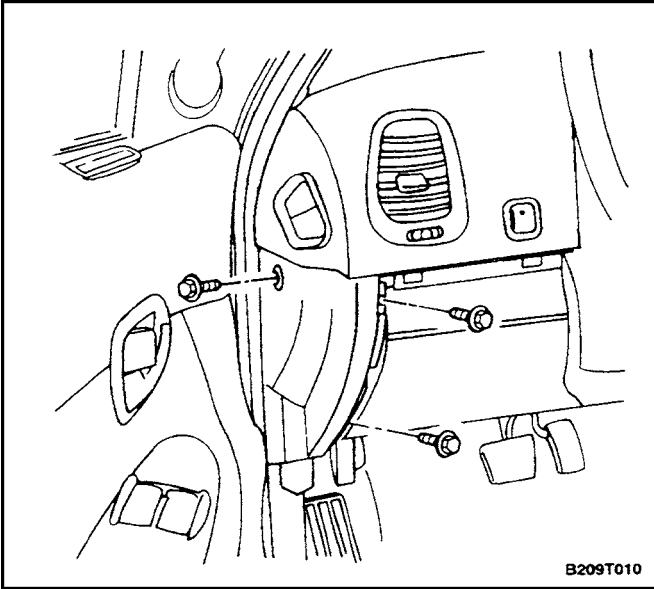

2. Slide the knee bolster trim panel upward and pull it outward to remove it.
3. Remove the instrument panel side cover.

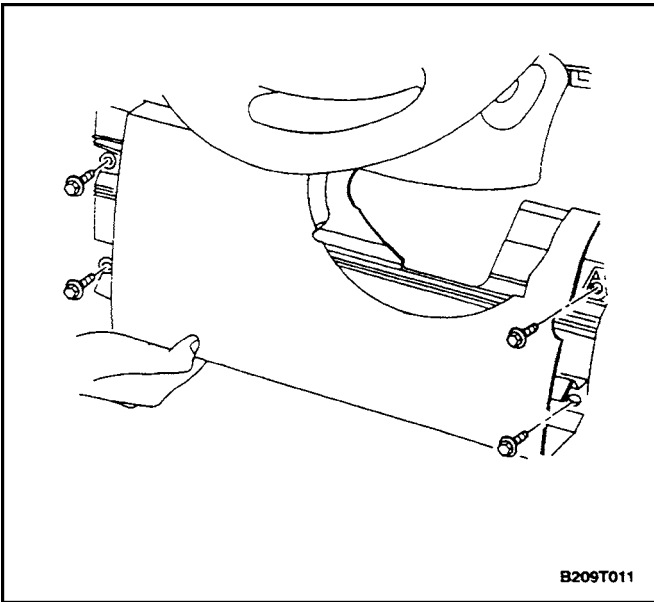

4. Remove the bolts and the knee bolster.

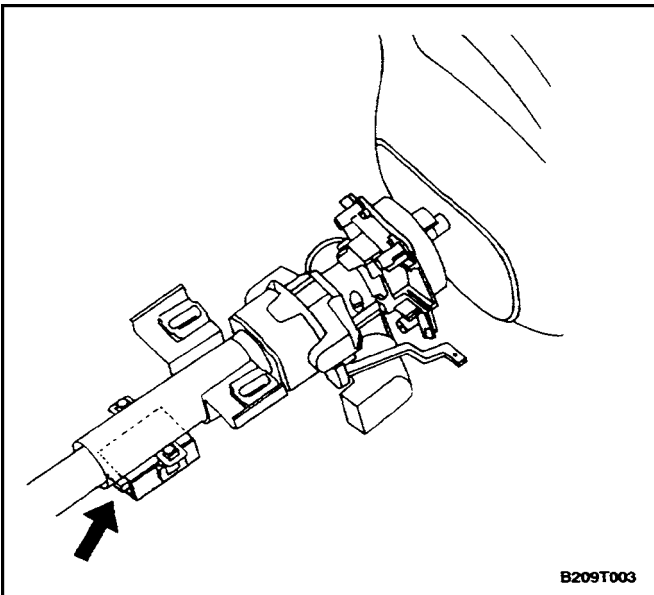

5. Remove the steering column lower cover. Refer to *Section 6E, Steering Wheel and Column*.
6. Disconnect the two-pin connector from the immobilizer.

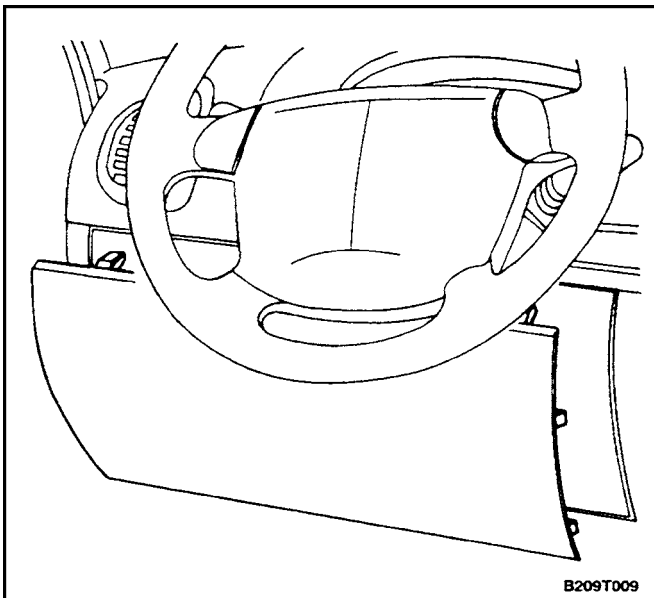
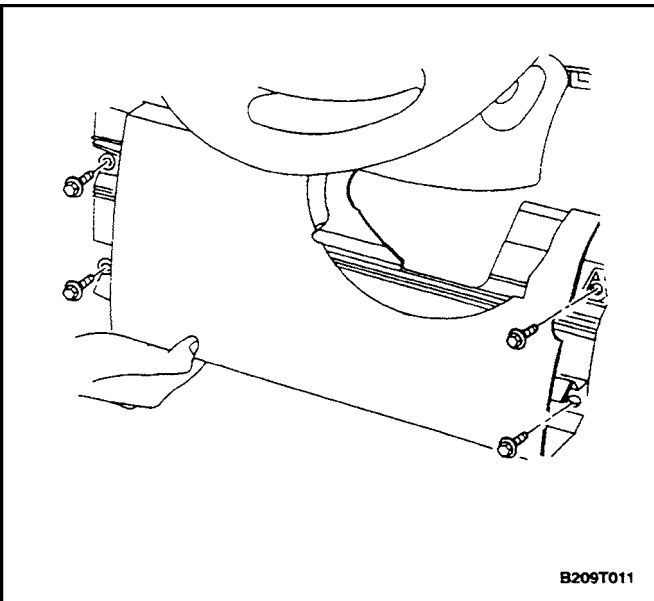
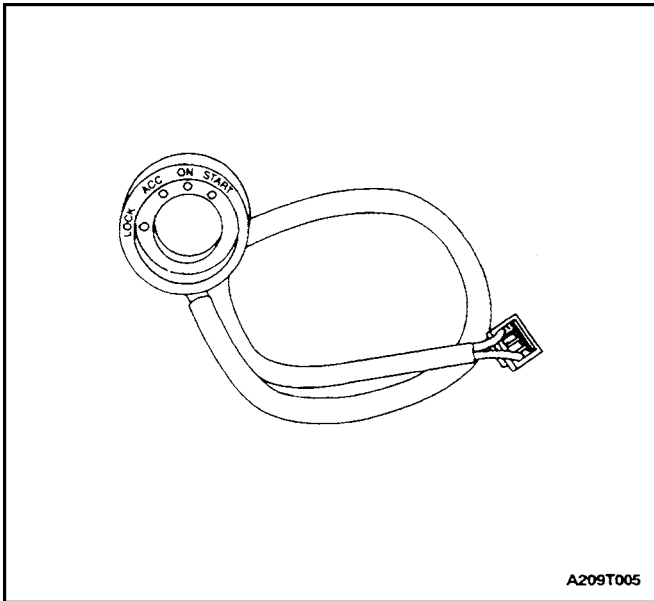

7. Pry the detection coil away from the lock cylinder. If the detection coil will be replaced with a new one, it does not matter if the key position trim ring is damaged during removal. A new trim ring is part of the new detection coil.

Installation Procedure

1. Install the detection coil by pressing it onto the lock cylinder until it snaps in place.
2. Connect the two-pin connector to the immobilizer.
3. Install the steering column lower cover. Refer to *Section 6E, Steering Wheel and Column*.
4. Install the knee bolster with the bolts.

Tighten

Tighten the knee bolster mounting bolts to 22 N•m (16 lb–ft)

5. Install the instrument panel side cover.
6. Install the knee bolster trim panel.

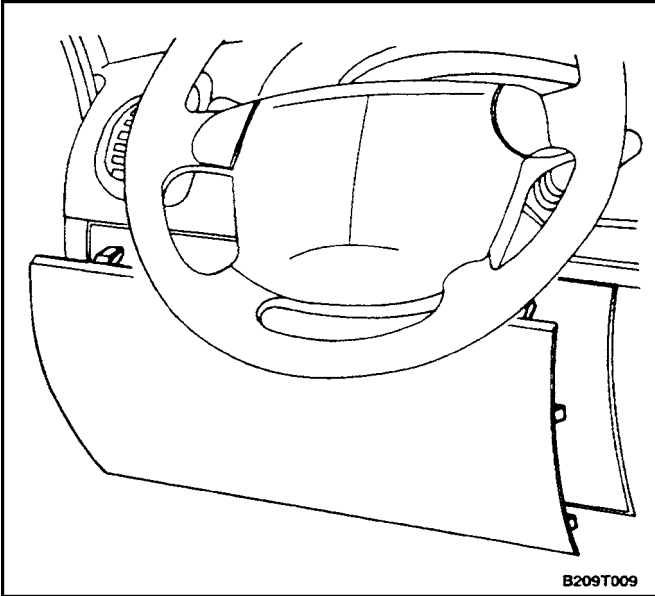

IMMOBILIZER CONTROL UNIT

Removal Procedure

1. Disconnect the negative battery cable.
2. Carefully pull the knee bolster trim panel loose from its retaining clips.

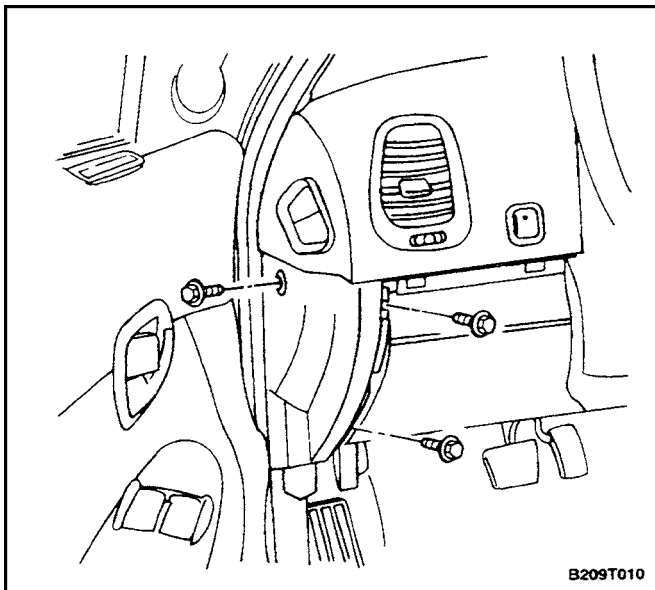

3. Slide the knee bolster trim panel upward and pull it outward to remove it.
4. Remove the instrument panel side cover.

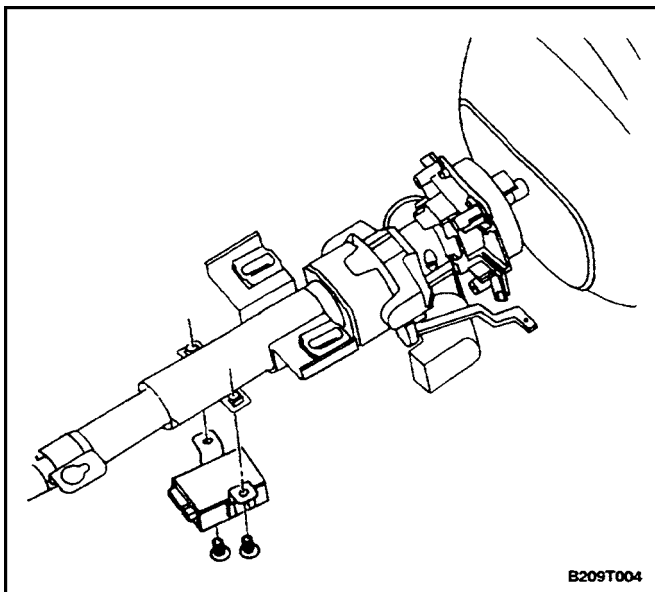

5. Remove the bolts and the knee bolster.
6. Remove the bolts and the immobilizer control unit.
7. Disconnect the electrical connectors from the immobilizer control unit.

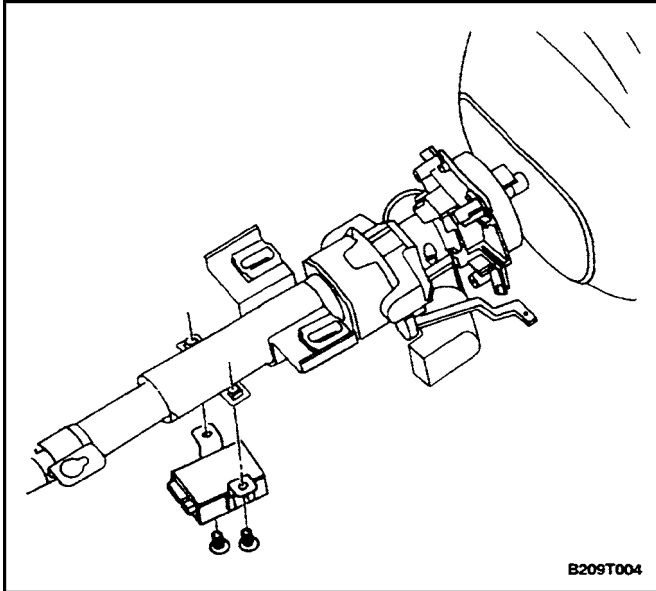

Installation Procedure

1. Connect the electrical connectors to the immobilizer control unit.
2. Install the immobilizer control unit with the bolts.

Tighten

Tighten the immobilizer control unit mounting bolts to 4 N•m (35 lb-in).

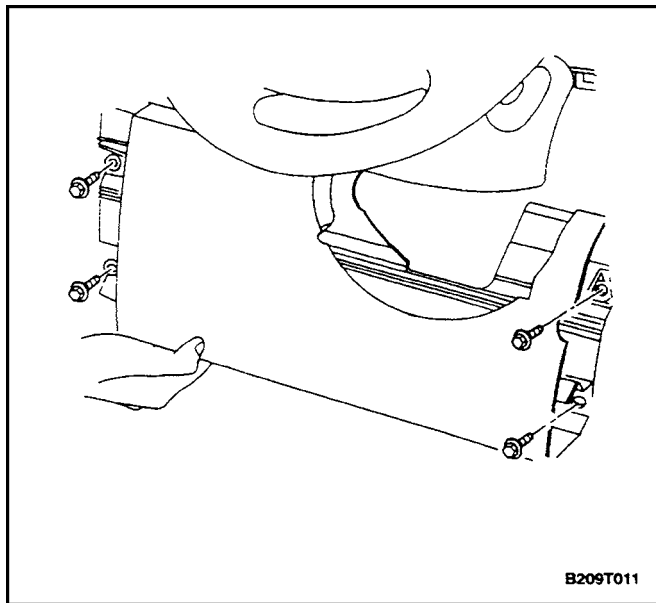

3. Install the knee bolster with the bolts.

Tighten

Tighten the knee bolster mounting bolts to 22 N•m (16 lb-in).

4. Install the instrument panel side cover.
5. Install the knee bolster trim panel.
6. Connect the negative battery cable.

Important : After replacing the immobilizer, the keys must be re-authorized using the key coding procedure. Refer to "Key Coding Procedure" in this section. Also, the electronic control module (ECM) identification (ID) code must be reset. Refer to "ID Code Reprogramming" in this section.

GENERAL DESCRIPTION AND SYSTEM OPERATION

IMMOBILIZER SYSTEM

The purpose of the immobilizer system is to prevent the vehicle from being stolen or driven by unauthorized users. Users are authorized by an electronically coded key.

When the ignition is turned ON, the key is tested by the immobilizer system. While the key code is being read by the immobilizer control unit, the engine can start and run with any key that will turn the lock cylinder. The key code is read and compared with key codes that have been stored in the immobilizer control unit's memory.

If a valid key is detected, the immobilizer control unit sends a serial data release message to the powertrain control module (PCM)/engine control module (ECM). Included in the release message is an identification (ID) code which assures that neither the immobilizer control unit nor the PCM/ECM has been substituted to defeat the system.

If the PCM/ECM does not receive a release message within a specified time, or if the ID codes do not match, the PCM/ECM performs the following actions:

- Disables the fuel injector circuit.
- Disables the fuel pump circuit.
- Disables the ignition coil.
- Sets diagnostic trouble code (DTC) 53.

The above conditions are maintained until the ignition is turned OFF.

The immobilizer control unit system consists of the following components:

- Electronically coded keys.
- Detection coil.
- Immobilizer control unit.
- PCM/ECM.
- Instrument cluster indicator.
- A data link connector (DLC) to provide serial data access for a scan tool.

A PCM/ECM for a vehicle without an immobilizer control unit cannot be interchanged with a PCM/ECM that is used with an immobilizer control unit system. The immobilizer control unit and the PCM/ECM must have a matching ID code. ID coding and key coding are accomplished by using a scan tool.

ELECTRONICALLY CODED KEYS

Each valid ignition key has an internal transponder which transmits a unique code. When a key is inserted into the ignition lock, the transponder is inductively coupled to the detection coil. The transponder interacts with the detection coil to generate an amplitude modulated signal which is conducted from the detection coil to the immobilizer control unit. The immobilizer control unit reads

the radio-frequency signal. A release message is sent to the powertrain control module (PCM)/engine control module (ECM) if the key is authorized.

New keys are coded by using a scan tool. Refer to in this section. "Key Coding Procedure"

DETECTION COIL

A detection coil is mounted at the ignition lock as an integral part of the key position trim ring. The wires to and from the detection coil are connected to the immobilizer. When the ignition is turned ON, the immobilizer energizes the detection coil and the coil is coupled inductively to the transponder in the ignition key. The immobilizer sends a modulated signal to the detection coil. The signal is changed by interaction with the internal transponder in the ignition key. The immobilizer reads the signal from the detection coil and determines whether the key is authorized.

IMMOBILIZER CONTROL UNIT

The immobilizer control unit is an electronic module in the instrument panel which verifies the validity of an ignition key when the ignition is turned ON.

To accomplish its purpose, the immobilizer control unit performs the following actions:

- Learns and stores the codes of valid keys.
- Reads the radio frequency input from the ignition key.
- Compares the received code with the codes of the valid keys.
- Sends a release message to the powertrain control module (PCM)/engine control module (ECM) if a valid key has been presented.
- Calculates and transmits identification (ID) codes within each release message.
- Controls the external relay which interrupts the starter relay circuit.
- Controls the status indicator in the instrument cluster.
- Monitors system faults.
- Supports system test functions.

Normal Operation

When the ignition is turned ON, the immobilizer control unit tries to read the key code transmitted by the transponder in the ignition key.

If a valid key is detected, the immobilizer control unit sends a release message to the PCM/ECM. The release message contains an ID code. Immobilization will be performed by the PCM/ECM if no release message is received, or if the ID code in the PCM/ECM does not match the immobilizer control unit ID code.

If a non-valid key is detected, the release message is not sent to the PCM/ECM.

When the driver turns the ignition OFF, the immobilizer control unit switches to the active mode.

Data Link Connector (DLC)

When the ignition is ON, a scan tool can switch the immobilizer control unit to the data link connector (DLC) mode for the purpose of diagnostics, key coding, or ID coding.

ID Code Handling

One of 65,535 possible ID codes is stored in the immobilizer control unit's memory.

The ID code can be erased by using the scan tools' RESET ID CODE command. When the immobilizer control unit calculates a new ID code, the PCM/ECM ID code must be reset to match the immobilizer control unit ID code. To reset the ID code, refer to "ID Code Reprogramming."

During diagnostic procedures, the ID code can be read for comparison with the PCM/ECM ID code by using the scan tool's READ IMMOBILIZER CONTROL UNIT IDCODE command.

SERIAL DATA LINK

Serial data can be exchanged between a scan tool, the powertrain control module (PCM)/engine control module (ECM), and the immobilizer control unit.

The scan tool connection is the data link connector (DLC).

POWERTRAIN CONTROL MODULE (PCM)/ENGINE CONTROL MODULE (ECM)

When the powertrain control module (PCM)/engine con-

trol module (ECM) detects that the ignition is being turned ON, the PCM/ECM waits for a release message from the immobilizer control unit. If a release message is not received within a specified time, the PCM/ECM disables the engine. The engine is also disabled if the identification (ID) code transmitted by the immobilizer control unit does not match the code stored in the PCM/ECM's memory. Immobilization remains in effect until the ignition is turned OFF, or until battery power is removed.

To prevent the vehicle from being driven, the PCM/ECM applies the following strategy:

- The ignition module is put in a bypass mode.
- The PCM/ECM will not create an electronic spark timing (EST) output. Therefore, no spark will be generated by the ignition coil.
- The PCM/ECM will not enable the fuel pump.
- The PCM/ECM will not enable the fuel injectors.
- The PCM/ECM sets diagnostic trouble code (DTC) 53.

Serial data communication is transmitted on a single wire between the immobilizer control unit and the PCM/ECM.

During diagnostic procedures or ID code changing, a scan tool is added to the communication system.

A PCM/ECM with an immobilizer control unit is not exchangeable with a PCM/ECM that does not have an immobilizer control unit.